

# ASD-50



Some options shown

WS Packaging Group - Automated Systems custom manufactures some of the world's highest quality and most dependable applicators. The added value of rugged state of the art components guarantees years of low-maintenance production.

## System Description:

The ASD-50 utilizes a "Keep-it-Simple" design to offer easy operation and minimal downtime by providing quick access to all maintenance parts. The ASD-50's thick base plate, oversized shafts, and sealed bearings make it the most durable labeling head on the market. Flexible for roll-on, tamp, blow, and tamp/blow technology, the ASD-50 labeler offers the flexibility to apply different types of pressure sensitive labels to the side, top, bottom, or corner of almost any shaped product. The ASD-50 can operate as a stand-alone labeler or it can be integrated with a wide variety of product handling devices.

## Standard Features:

- Allen Bradley PLC controls, the most common and trusted industrial control provider in U.S. manufacturing today
- Roll-on technology
- No Nip Pull Roll
- Vertical Lead Screw
- High-quality stepper motor
- Pull roll safety switch
- Proprietary support stand design
- Non-corrosive parts
- Casters



**WS Packaging Group**® - Automated Systems

Leaders in Printing and Packaging Worldwide

[www.wspackaging.com](http://www.wspackaging.com)

13 Carry Way  
Carson City, NV 89706

Phone: 775-246-5977  
Fax: 775-246-7169

7500 Industrial Row Drive  
Mason, OH 45040-1307

Toll-free: 800-877-3795  
Phone: 513-459-8400  
Fax: 513-459-8412

# ASD-50

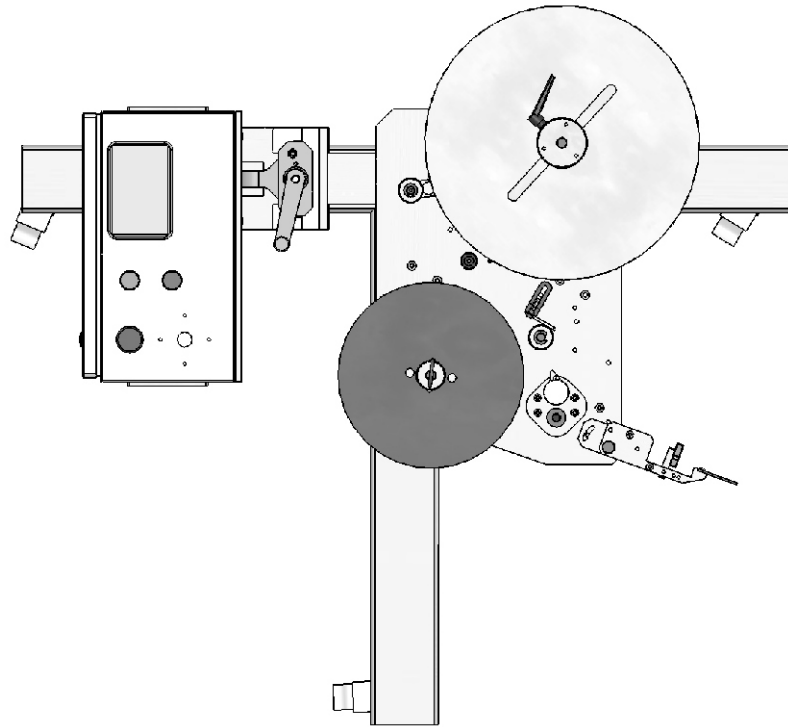

## Options:

- Tamp, blow, tamp/blow technology
- Static control
- Touch Screen operator interface
- Clear label detection
- Stainless steel T-Base
- Stainless steel NEMA control enclosure
- Bottle turner
- Product pacing control
- Conveyors available in various sizes and configurations
- Bi-lingual display
- Three color light indicator
- 16" O.D. label roll supply
- Horizontal lead screw adjustment
- Remote mount operator interface
- Flow Gates
- Label "Skip" option
- Fan-fold label supply

## Specifications:

### Label Dimensions:

Up to 6" web width

### Label Roll Requirements:

Finish: Die cut pressure sensitive labels with minimum spacing of 1/8" between labels in feed direction

Outside Diameter: up to 12"; 16" optional

Inside Diameter (Core): 3"; 6" optional

### Machine Dimensions

Labeling Head:

Length: 29"

Width: 20"

Height: 21"

### Labeling Stand:

Length: 40"

Width: 36"

### Service/Utility Requirements:

Electrical: 110VAC, 60 cycle, Single Phase, 10 amps

## Available application options:

